

DATASHEET

BACK PRESSURE MAINTAINING VALVE (BPMV): H210 AND H211

MODEL CODE							
H210	1	1	AA	75P	N	NY	0

MODEL TYPE	
H210	DOME LOADED INTERNALLY
H211	DOME LOADED EXTERNALLY

MAXIMUM INLET PRESSURE	
1	6,000 Psi (414 Bar)
2	4,000 Psi (272 Bar)
2	3,500 Psi (238 Bar)

SET PRESSURE RANGE	
1	44 ~ 6,000 Psi (3 ~ 414 Bar)
2	44 ~ 4,000 Psi (3 ~ 272 Bar)
3	44 ~ 3,500 Psi (3 ~ 238 Bar)

MATERIAL	
AA	ALUMINIUM ALLOY
SS	STAINLESS STEEL
AB	ALUMINIUM BRONZE
BR	BRASS

GAUGE PORT	
0	NO PORT
GI	1/4" BSPP INLET
GO	1/4" BSPP OUTLET
GB	1/4" BSPP INLET & OUTLET

SEAT MATERIAL	
NY	NYLON

SEALS	
N	NITRILE
V	VITON

PORTING	
75P	3/4" BSPP
75N	3/4" NPT

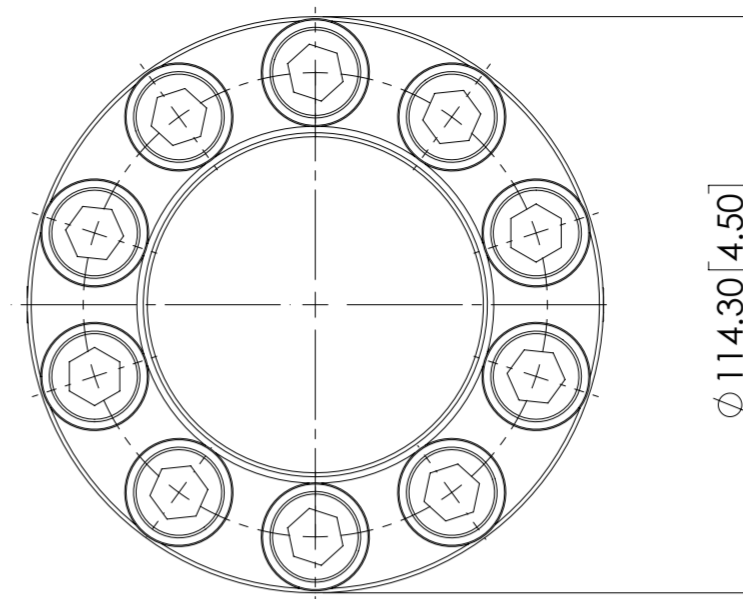

SPECIFICATION

- ORIFICE: 12.7mm
- MEDIUM: H210 - GAS ONLY
- MEDIUM: H211 - GAS AND LIQUID
- DRY WEIGHT: 5.0 kg (11.0 lb)
(ALUMINIUM ALLOY)

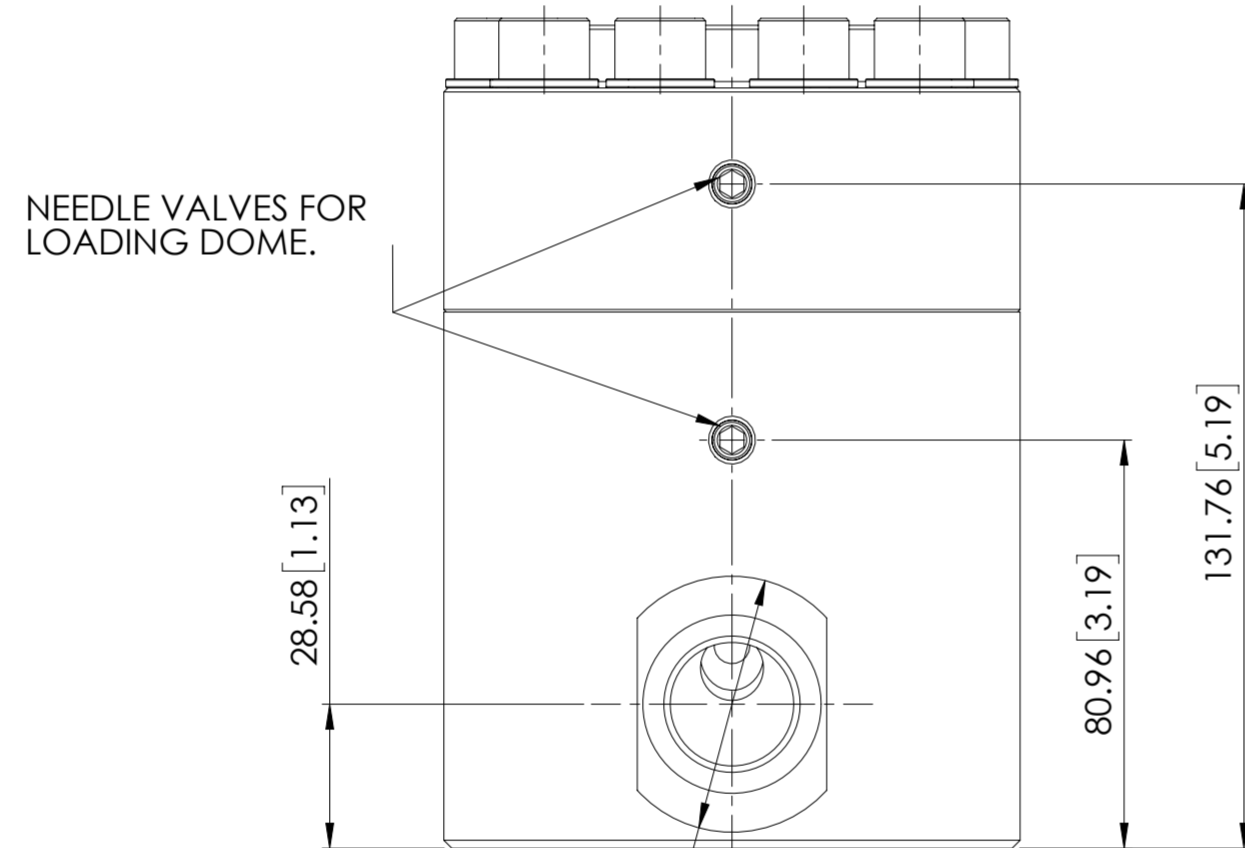
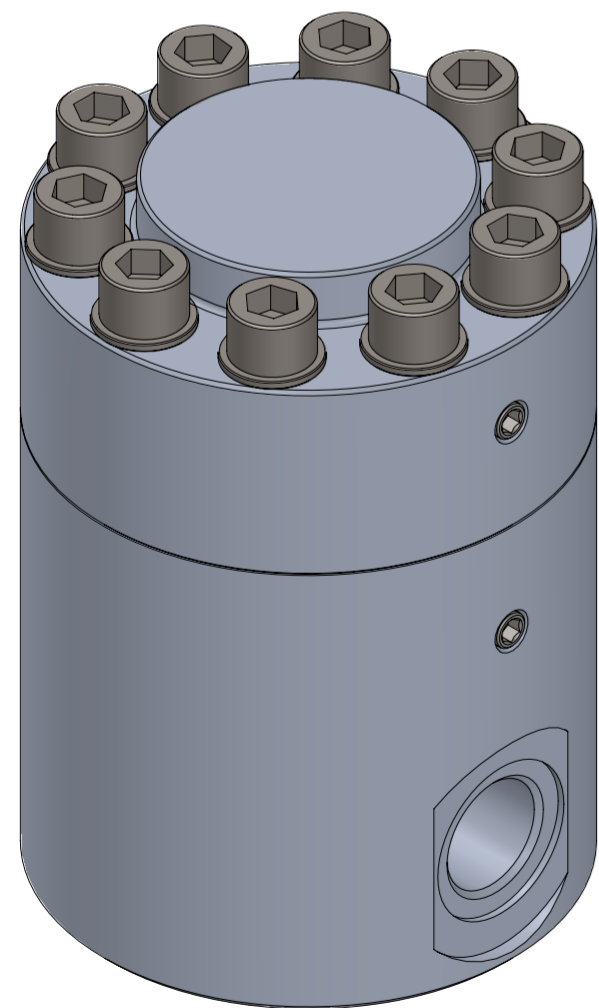

Ø 50.80 [2.00] SPOT FACES
TYP BOTH PORTS

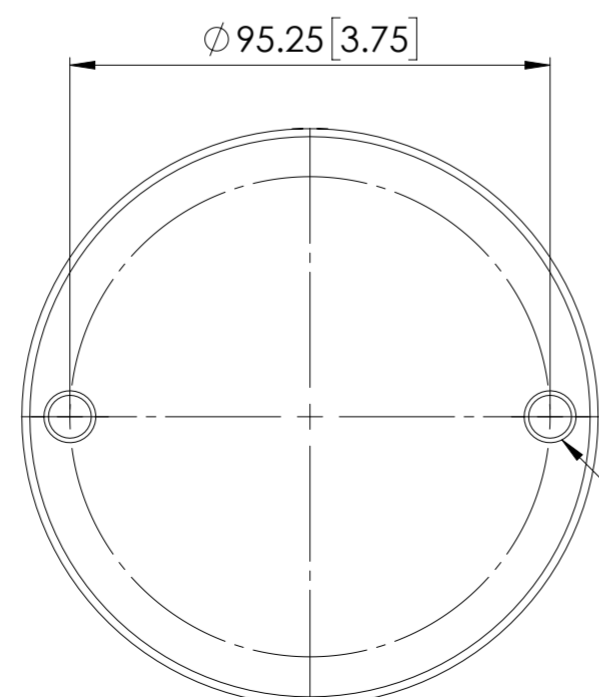

2 OFF MOUNTING HOLES
M10 x 12.7mm FULL
THREAD (0.50")

Ø 35.42 [1.39] C/BORE
Ø 35.29 [1.39]
ONLY APPLIES TO
BSPP PORTED VALVES

1.6 [0.06] C/BORE
ONLY APPLIES TO
BSPP PORTED VALVES



53.98 [2.13]

107.95 [4.25] SPOT FACE
TO SPOT FACE

H211 VALVES ONLY. 1/8" BSPP
EXTERNAL DOME LOADING PORT
LOCATION. (PORT NOT SHOWN)

NEEDLE VALVE FOR
VENTING DOME.

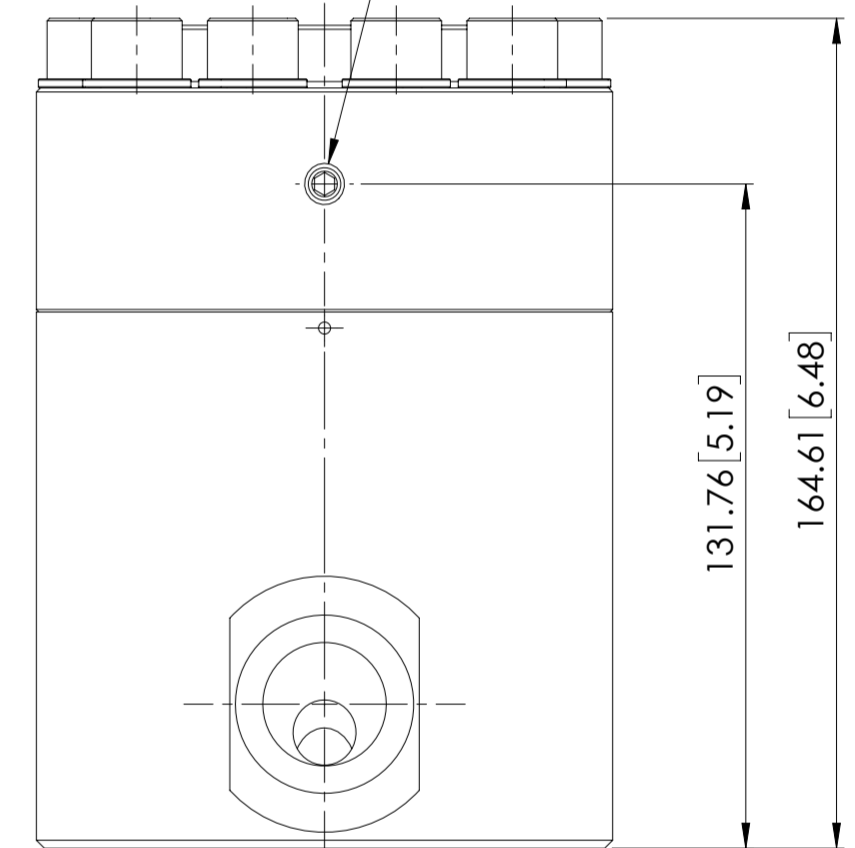

© AND DESIGN RIGHT BIS WELLS LTD. ALL RIGHTS RESERVED. WITHOUT THE PRIOR WRITTEN PERMISSION OF BIS WELLS LTD NO PART OF THIS DOCUMENT MAY BE ALTERED, ADAPTED, PUBLISHED, REPRODUCED OR TRANSMITTED IN ANY FORM OR MEDIUM.				UNLESS OTHERWISE SPECIFIED DIMENSIONS ARE IN INCHES 1. LINEAR TOLERANCES : ±0.1" 2. ANGULAR TOLERANCES : ±2°						
DRAWN	J.PHELAN	SHEET	1 OF 1	 3RD ANGLE PROJECTION	DRAWING SIZE	A2	DRAWING SCALE	1:2	DRAWING NUMBER	DS0005
DATE	03/05/19	ISSUE	1							