

Installation Operation and Maintenance Manual

A220 & A221 DOME LOADED PRESSURE REDUCING VALVE



THIS DOCUMENT is only applicable to the service of A220 and A221 valves only. General instructions regarding installation, operation and maintenance for all types of dome loaded pressure reducing valves must be read prior.

TYPE A220 & A221 OPERATING INSTRUCTIONS

A220: INTERNALLY LOADED
A221: EXTERNALLY LOADED

OPERATING INSTRUCTIONS.

To aid setting it is advisable to have a pressure gauge and isolating stop valve available downstream of the reducing valve, this will enable a small downstream volume to be isolated, and will allow accurate indication of downstream control pressure and precise and positive adjustment.

Internal Charging of Dome – A220 Valves only.

Note: The A220 has common (A) and (B) ports allowing the valve to be set from both sides.

1. Ensure all needle valves are firmly closed.
2. Check the dome is de-pressurised by opening the dome needle valve (A) one full turn and then close firmly when no gas is escaping from the needle valve.
3. Apply pressure to the inlet port. No downstream flow should occur.
4. Open line needle valve (B) one full turn, gas may escape from around the needle valve – this is normal.
5. Observe the downstream pressure gauge and gently crack open the dome needle (A) keeping the socket key in position in the needle valve. Allow the pressure to feed into the dome and outlet pressure to rise to the desired value.
6. Quickly close the dome needle valve (A).
7. Close the line needle valve (B).

ADJUSTMENTS.

The correct outlet pressure should now be set but if the pressure is too high it can be reduced by gently cracking the vent needle valve (B) to release pressure from the dome this will allow the set pressure to fall.

Ensure all needle valves are secure when setting is finalised.

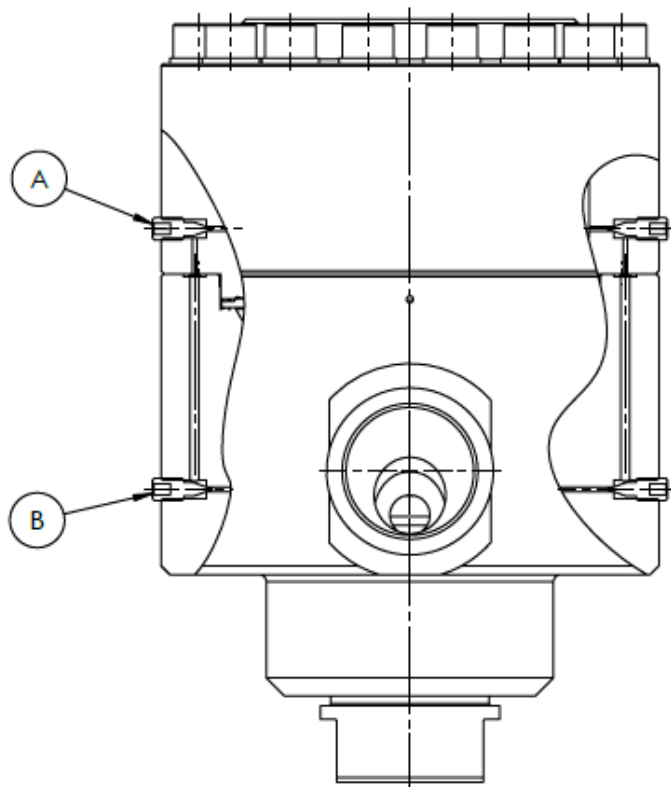

External Charging of Dome – A221 Valves only.

1. Ensure both (A) and (B) needle valves are firmly closed.
2. Check dome is de-pressurised by opening the vent needle valve (A) one full turn and then close firmly when no gas is escaping from the needle valve.
3. Apply pressure to the inlet port. No downstream flow should occur.
4. Connect the pilot pressure supply to the dome charging port and apply suitable pressure.
5. Observe the downstream pressure gauge and gently crack open the dome needle (B) keeping the socket key in position in the needle valve. Allow the pressure to feed into the dome and outlet pressure to rise to the desired value.
6. Quickly close the dome needle valve (B).

ADJUSTMENTS.

The correct outlet pressure should now be set but if the pressure is too high it can be reduced by gently cracking the vent needle valve (A) to release pressure from the dome this will allow the set pressure to fall. Ensure all needle valves are secure when setting is finalised.

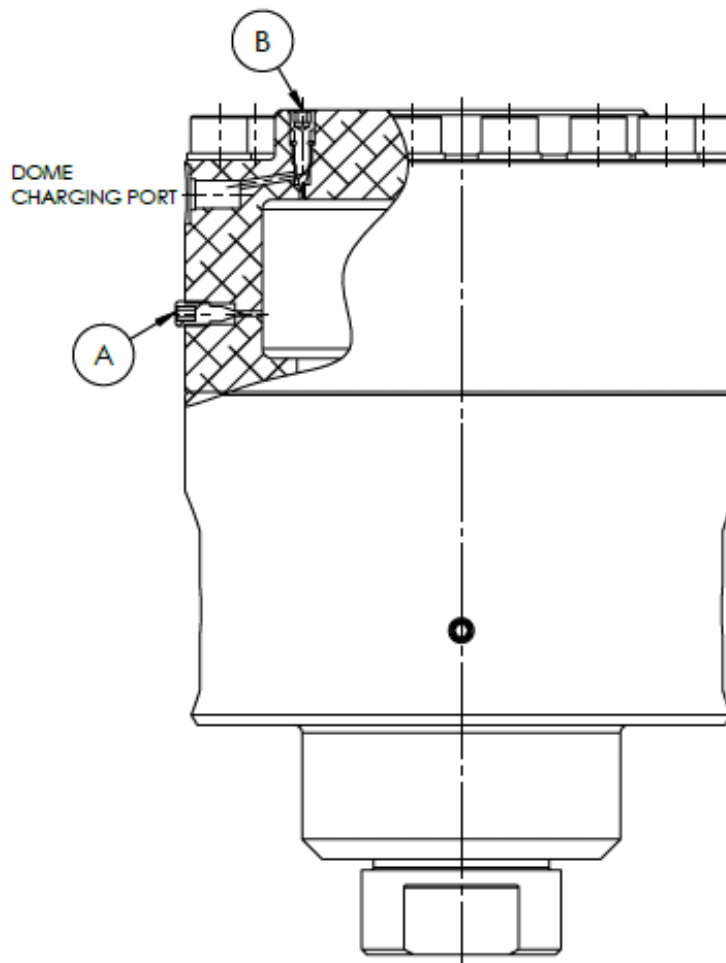

DOME LOADED PRESSURE REDUCING VALVE **SERVICE INSTRUCTIONS.**

These instructions are confined to the replacement of the Diaphragm and O-Ring seal, Valve Seat and Valve Plunger only. Any damage caused to other components would require the units return to the manufacturer.

Before undertaking any servicing of the valve, ensure the valve is completely isolated from the supply and outlet pressures, any pressure in the valve has been removed and the dome has been de-pressurised by unscrewing all needle valves one full turn.

Before commencing the valve refurbishment, it is recommended that the valve is removed from the line and worked on in a clean environment.

Cleanliness during assembly is most important, particularly on all sealing surfaces.

BEFORE SERVICE, REFER TO THE DOME LOADED PRESSURE REDUCING VALVES GENERAL INSTRUCTIONS

Diaphragm replacement. (Top End)

1. Unscrew the dome securing screws (1) complete with washers (2), then separate the dome (3) from the body (14).
2. Remove the old diaphragm (6) and the O-ring (13).
3. Remove valve plunger, spring washer and conical spring (8,9,10)
4. Inspect all components for damage and wear before re-assembly. Replace parts as required.
5. Fit the new diaphragm (6), O- ring (13) and conical spring (10) ensuring all mating parts are clean and damage free.
6. Secure the dome (3) with screws (1) complete with washers (2) and torque to 95 - 100Nm.

Valve seat, Valve and O-Ring replacement. (Bottom End)

1. Unscrew the body plug (24) and remove from the valve body (14). Remove the spring (23) and spring support (22). Take care not to lose or damage O-ring (15).
2. Pull the valve assembly from the body (14). The valve assembly comprises of parts: (15), (16), (17), (18), (19), (20), (21), and (22).
3. Push the valve (18) up through item (21). This will free and remove the valve seat (17), along with O-ring (15) and seat support (16).
4. Remove all seals.
5. Inspect all components for damage and wear. Replace parts as required.
6. Ensure all parts are clean before re-assembly.
7. Fit new O-ring (19) onto new valve (18). Push item 18 complete with item 19 into item 21.
8. Fit new O-rings (20) & (15) new valve seat (17), and new seat support (16) and lubricate with a suitable lubricant. The valve assembly is now rebuilt.
9. Push the valve assembly in the valve body (14) as per exploded view.
10. Refit spring support (22) along with a new spring (23) & new O-ring (15)
11. Screw the body plug (24) into the body (14) and torque to 90 – 95Nm.
12. Before refitting the valve to the system, it is advisable to check for leaks on a test rig suitable for this purpose.

NOTE: Ensure lubricants are compatible with the system medium.

A220 EXPLODED VIEW

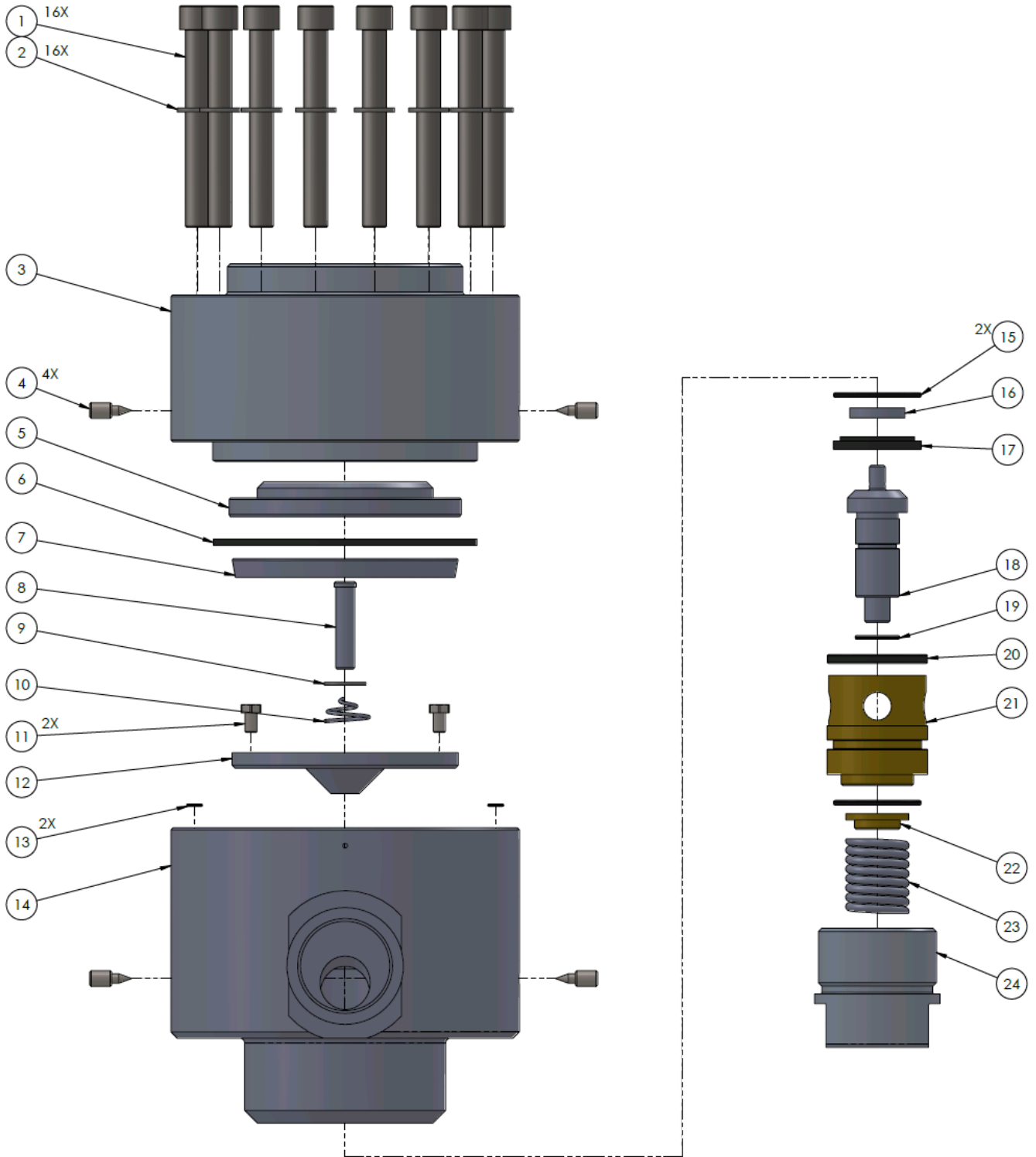

A221 EXPLODED VIEW ADDITIONAL DETAIL

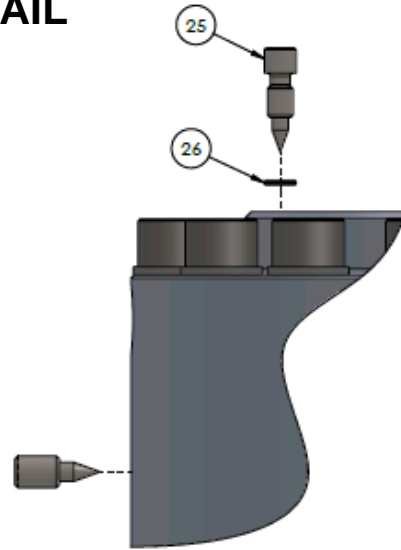

RECOMMENDED SPARES KIT

A220 STANDARD VALVE

ITEM	DESCRIPTION	QUANTITY
17	Valve Seat	1
6	Diaphragm	1
10	Conical Spring	1
23	Spring	1
16	Valve Seat Support	1
13	O-Ring	2
15	O-Ring	2
19	O-Ring	1
20	O-Ring	1

A221 STANDARD VALVE

ITEM	DESCRIPTION	QUANTITY
17	Valve Seat	1
6	Diaphragm	1
10	Conical Spring	1
23	Spring	1
16	Valve Seat Support	1
15	O-Ring	2
19	O-Ring	1
20	O-Ring	1
26	O-Ring	1