

## **Installation Operation and Maintenance Manual**

**H200 & H201**

**DOME LOADED BACK PRESSURE MAINTAINING VALVE**

**THIS DOCUMENT** is only applicable to the service of H200 and H201 valves only. General instructions regarding installation, operation and maintenance for all types of dome loaded back pressure maintaining valves (BPMV) must be read prior.

## TYPE H200 & H201 OPERATING INSTRUCTIONS

**H200: INTERNALLY LOADED**  
**H201: EXTERNALLY LOADED**

### OPERATING INSTRUCTIONS.

To aid valve setting it is advisable to have a pressure gauge available downstream of the BPMV, this will enable accurate indication of BPMV set pressure and precise and positive adjustment.

#### Internal Charging of Dome – H200 Valves only.

1. Ensure needle valves (A) and (B) are firmly closed.
2. Check the dome is de-pressurised by opening the dome needle valve (B) one full turn and then close firmly when no gas is escaping from the needle valve.
3. Ensure the outlet port is open to atmosphere.
4. Apply pressure to the inlet port. The valve should open, and flow should occur.
5. Shut off pressure to the inlet and open needle valve (A) one full turn.
6. Apply the desired set pressure to the inlet. The valve should not pass any flow.
7. Once the desired set pressure has been achieved close needle valve (A). Pressure is now locked in the dome and the valve is now set.
8. Shut off pressure to the inlet.
9. To test the valve, slowly increase the inlet pressure, when the set pressure is met the valve should open and pass flow. You may want to fit a pressure gauge to the outlet to a more positive indication of set pressure.

### ADJUSTMENTS.

If the set pressure is too high or too low the valve must be reset. First release pressure from the dome by gently cracking open vent needle valve (A), then follow the above steps to recharge the dome.

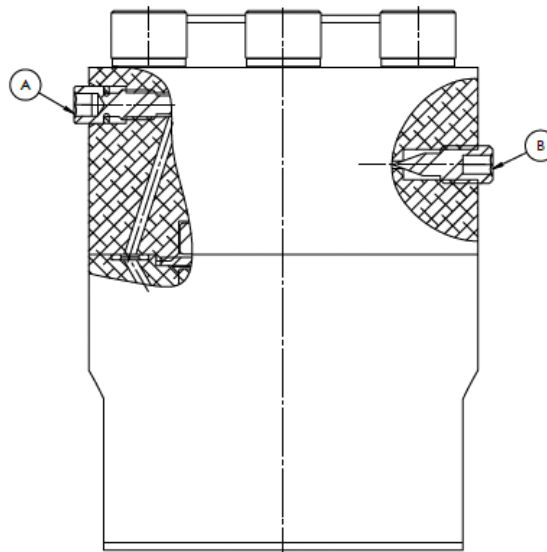

### External Charging of Dome – H201 Valves only.

1. Ensure needle valves (A) and (B) are firmly closed.
2. Check the dome is de-pressurised by opening the dome needle valve (B) one full turn and then close firmly when no gas is escaping from the needle valve.
3. Ensure the outlet port is open to atmosphere.
4. Apply pressure to the inlet port. The valve should open, and flow should occur.
5. Shut off pressure to the inlet and open needle valve (A) one full turn.
6. Apply the desired set pressure to the dome charging port.
7. Once the desired set pressure has been achieved close needle valve (A). Pressure is now locked in the dome and the valve is now set.
8. To test the valve, slowly increase the inlet pressure, when the set pressure is met the valve should open and pass flow. You may want to fit a pressure gauge to the outlet to a more positive indication of set pressure.

### ADJUSTMENTS.

If the set pressure is too high or too low the valve must be reset. First release pressure from the dome by gently cracking open vent needle valve (B), then follow the above steps to recharge the dome.

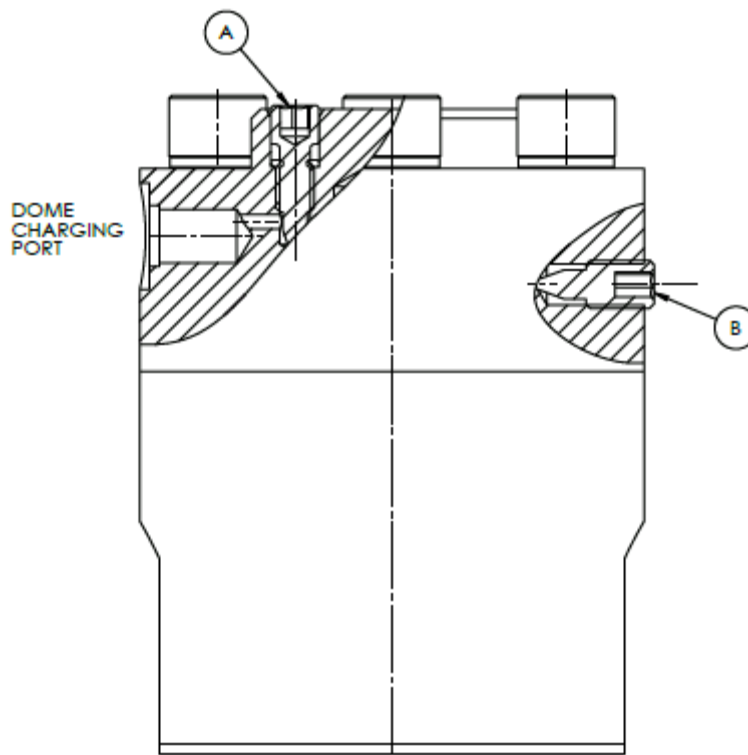

## **DOME LOADED PRESSURE REDUCING VALVE** **SERVICE INSTRUCTIONS.**

These instructions are confined to the replacement of the Diaphragm and O-Ring seals and Valve Seat only. Any damage caused to other components would require the units return to the manufacturer.

Before undertaking any servicing of the valve, ensure the valve is completely isolated from the supply and outlet pressures, any pressure in the valve has been removed and the dome has been de-pressurised by unscrewing all needle valves one full turn.

Before commencing the valve refurbishment, it is recommended that the valve is removed from the line and worked on in a clean environment.

Cleanliness during assembly is most important, particularly on all sealing surfaces.

### **BEFORE SERVICE, REFER TO THE DOME LOADED BACK PRESSURE MAINTAINING VALVES GENERAL INSTRUCTIONS**

#### **H200 & H201 SERVICING**

1. Unscrew the dome securing bolts (6) complete with washers (4) and separate the Dome (7) from the Body (8).
2. Remove spring (13).
3. Lift out the Diaphragm assembly (9, 3, 17, 10, 2, 11 & 12)
4. Unscrew the Valve Plunger Retaining Nut (12) from the Upper Diaphragm Plate (9) and remove the Plunger (11) and Spring (2).
5. Separate the Upper and Lower Diaphragm Plates (9,10) and remove the Diaphragm (3) and Guidance ring (17).
6. Check all components for damage or wear. Replace if necessary.
7. Fit the new Diaphragm (3), Guidance ring (17) and assemble between the Diaphragm Plates (9,10).
8. Fit the Plunger (11) and new Spring (2) and retain with the Retaining Nut (12). Torque to 10 – 12 Nm.
9. Unscrew the Seat Retainer (14) and remove the Seat (1) and O-Ring (4).
10. Fit the new Seat (1) and O-Ring (4) and secure with the Seat Retainer (14). Torque the Seat Retainer to 30 - 35 Nm.
11. Refit the Diaphragm assembly (9, 3, 17, 10, 2, 11 & 12) ensuring the Plunger (11) slides freely in the Seat Retainer (14). A light application of a suitable lubricant on the Plunger (11) is advisable.
12. Replace the Body O-Ring (5).
13. Fit the Spring (13) and place Dome (7) on the Body (8) and secure with the bolts (6). Tighten bolts to 55 – 60 Nm.
14. Remove the charging Needle Valve (15) and replace the O-Ring (5), refit the Needle Valve.
15. Check condition of Dome Vent Needle (16).
16. The Valve is ready for test and re-installation.

**NOTE:** Ensure lubricants are compatible with the system medium.

**H200 EXPLODED VIEW**

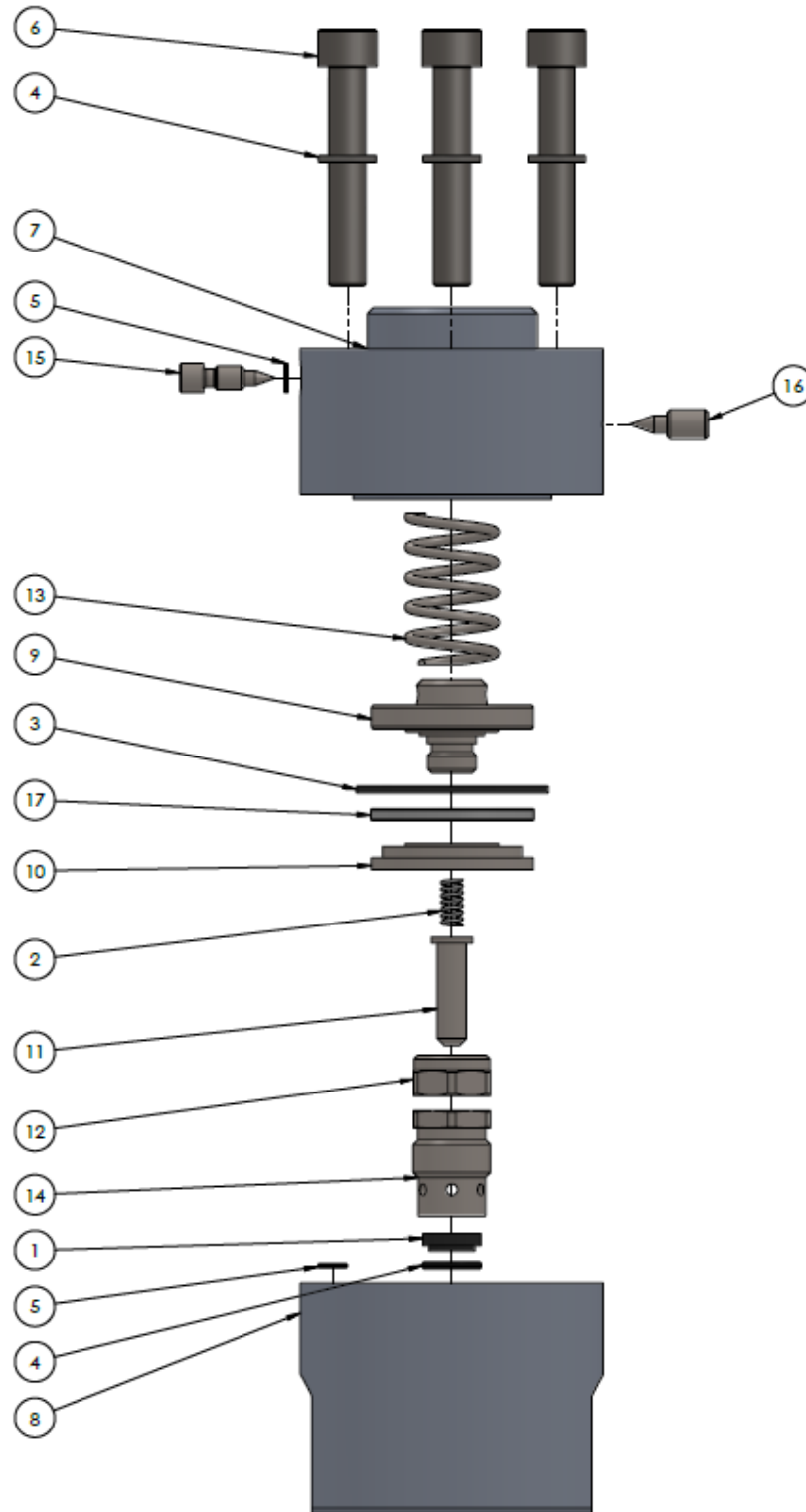

## H201 EXPLODED VIEW ADDITIONAL DETAIL

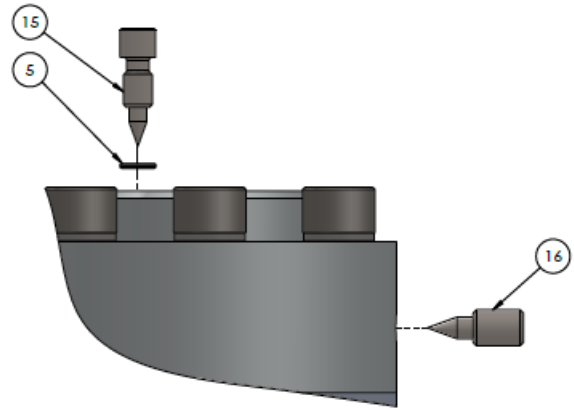

### RECOMMENDED SPARES KIT

#### H200 STANDARD VALVE

ITEM	DESCRIPTION	QUANTITY
1	Valve Seat	1
2	Valve Spring	1
3	Diaphragm	1
4	O-Ring	1
5	O-Ring	2
17	Guidance Ring	1

#### H201 STANDARD VALVE

ITEM	DESCRIPTION	QUANTITY
1	Valve Seat	1
2	Valve Spring	1
3	Diaphragm	1
4	O-Ring	1
5	O-Ring	1
17	Guidance Ring	1