

DATASHEET

RELIEF VALVES: C45

CE CATEGORY IV OF PRESSURE EQUIPMENT DIRECTIVE 2014/68/EU

MODEL CODE						
C45 -	1	1	SS	25P/25P	N	N

MODEL TYPE	
C45 -	RELIEF VALVE

MAXIMUM INLET PRESSURE	
1	40 Bar (580 Psi)

SET PRESSURE RANGE	
1	0.7 ~ 2.0 Bar (10 ~ 29 Psi)
2	2.0 ~ 10.0 Bar (29 ~ 145 Psi)
3	8.0 ~ 15.0 Bar (116 ~ 218 Psi)
4	13.0 ~ 26.0 Bar (189 ~ 377Psi)
5	23.0 ~ 40 Bar (334 ~ 580 Psi)
6	0 ~ 0.5 Bar (0 ~ 7 Psi)

EXTERNAL MATERIAL	
SS	STAINLESS STEEL

- FOR OXYGEN APPLICATIONS SEE THE **C45OX** DATA SHEET.
- FOR HYDROGEN APPLICATIONS SEE THE **C45H2** DATA SHEET.

SEAT MATERIAL	
N	NITRILE -30°C TO +105°C
V	FKM -10°C TO +120°C
H	HNBR -20°C TO +150°C
K	FFKM -25°C TO +200°C
OTHER SEAT MATERIALS AVAILABLE ON REQUEST	

SEAL MATERIAL	
N	NITRILE -30°C TO +105°C
V	FKM -10°C TO +120°C
H	HNBR -20°C TO +150°C
K	FFKM -25°C TO +200°C
OTHER SEAL MATERIALS AVAILABLE ON REQUEST	

PORTS	
25P/25P	1/4" BSPP INLET MALE & 1/4" BSPP OUTLET FEMALE
25N/25N	1/4" NPT INLET MALE & 1/4" NPT OUTLET FEMALE

VALVE INFORMATION	
APPROVALS	CATEGORY IV OF PRESSURE EQUIPMENT DIRECTIVE 2014/68/EU *
WEIGHT	0.15 Kg / (0.3 LB) (STAINLESS STEEL)
MEDIUM	GAS AND LIQUID
LEAKTIGHT	VIRTUALLY ZERO LEAKAGE WHEN 90% OF SET PRESSURE IS APPLIED
ORIFICE SIZE	Ø 5.0mm (0.197")
REPEATABILITY	GREATER OF 2 PSI OR +/-3% OF SET PRESSURE
MAX OUTLET PORT PRESSURE	10 BAR (145 Psi)

*NOTE - THE 0 - 0.5 BAR SET RANGE VALVE IS OUTSIDE THE SCOPE OF THE PRESSURE EQUIPMENT DIRECTIVE AND IS NOT CE MARKED.

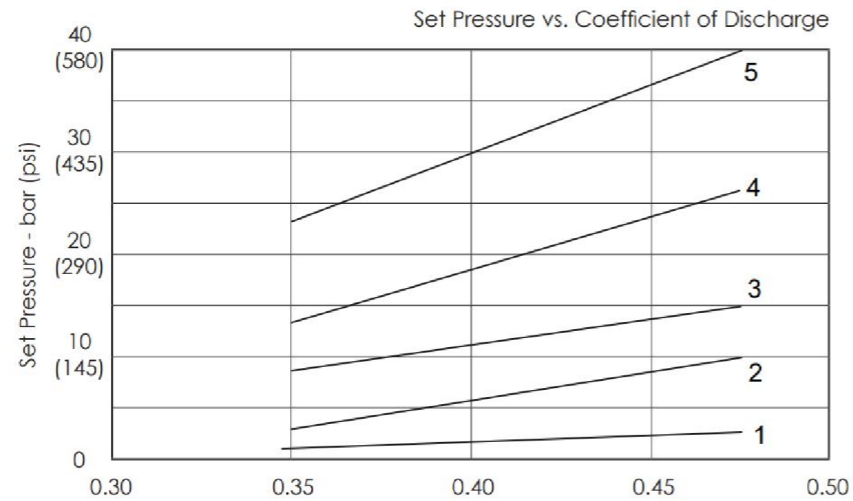
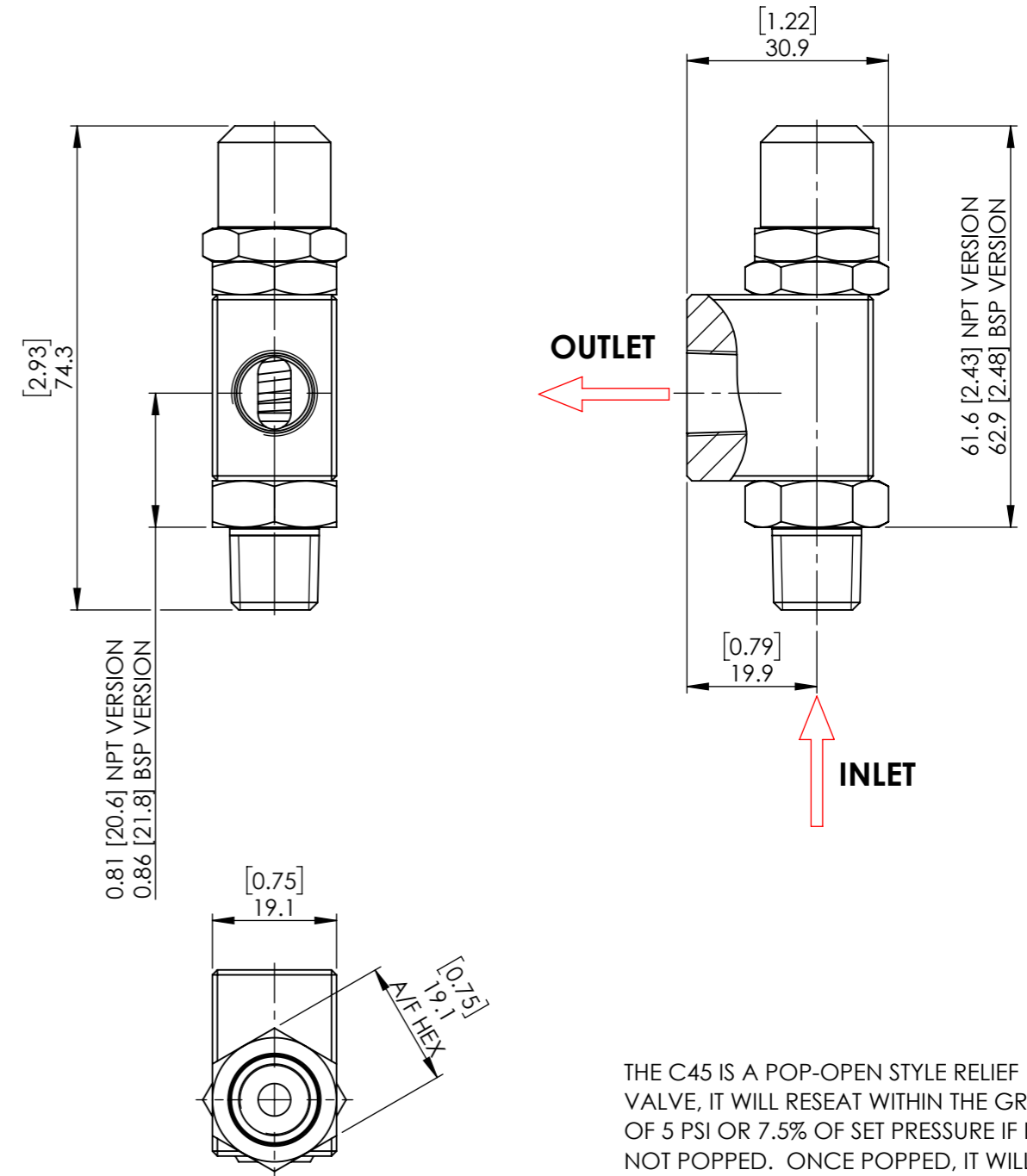

Certified Coefficient of Discharge (Kdr)

The Kdr value may be used to calculate discharge capacity in accordance with ISO 4126. We recommend contacting us with system details to confirm suitability.

THE C45 IS A POP-OPEN STYLE RELIEF VALVE, IT WILL RESEAT WITHIN THE GREATER OF 5 PSI OR 7.5% OF SET PRESSURE IF IT HAS NOT POPPED. ONCE POPPED, IT WILL RESEAT WITHIN 50% OF SET PRESSURE.



© AND DESIGN RIGHT Bis Wells LTD. ALL RIGHTS RESERVED. WITHOUT THE PRIOR WRITTEN PERMISSION OF Bis Wells Ltd NO PART OF THIS DOCUMENT MAY BE ALTERED, ADAPTED, PUBLISHED, REPRODUCED OR TRANSMITTED IN ANY FORM OR MEDIUM.

UNLESS OTHERWISE SPECIFIED, DIMENSIONS ARE IN MILLIMETRES. ALTERNATIVE DIMENSIONS IN SQUARE BRACKETS ARE IN INCHES.

DRAWN J.PHELAN	SHEET 1 OF 1	3RD ANGLE PROJECTION	DRAWING SIZE A3	DRAWING SCALE 1:1	DRAWING NUMBER DS0065
DATE 01/10/20	ISSUE 3				