

DATASHEET

DIRECTIONAL CONTROL VALVE (DCV): K39 & K39S

MODEL CODE						
K39 -	1	1	AA	75P	N	NY

MODEL TYPE	
K39 -	K39 (2 POSITION PRESSURE BIASED DCV) NORMALLY CLOSED.
K39S	K39S (2 POSITION PRESSURE BIASED DCV) NORMALLY CLOSED. HIGH FLOW

MAXIMUM INLET PRESSURE	
1	450 Bar (6,500 Psi)

PILOT PRESSURE RANGE	
1	80 ~ 120 Psi (5.5 ~ 8.3 Bar)
2	60 ~ 120 Psi (4.2 ~ 8.3 Bar)

MATERIAL	
AA	ALUMINIUM ALLOY
SS	STAINLESS STEEL
AB	ALUMINIUM BRONZE
BR	BRASS

SEAT MATERIAL	
NY	NYLON

SEALS	
N	NITRILE
V	VITON
OTHER MATERIALS AVAILABLE ON REQUEST	

PORTING	
75P	3/4" BSPP
75N	3/4" NPT

VALVE SYMBOL

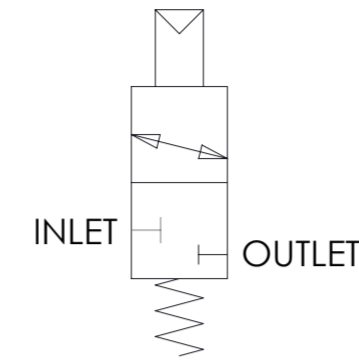

PILOT PORT (1/4" BSPP)

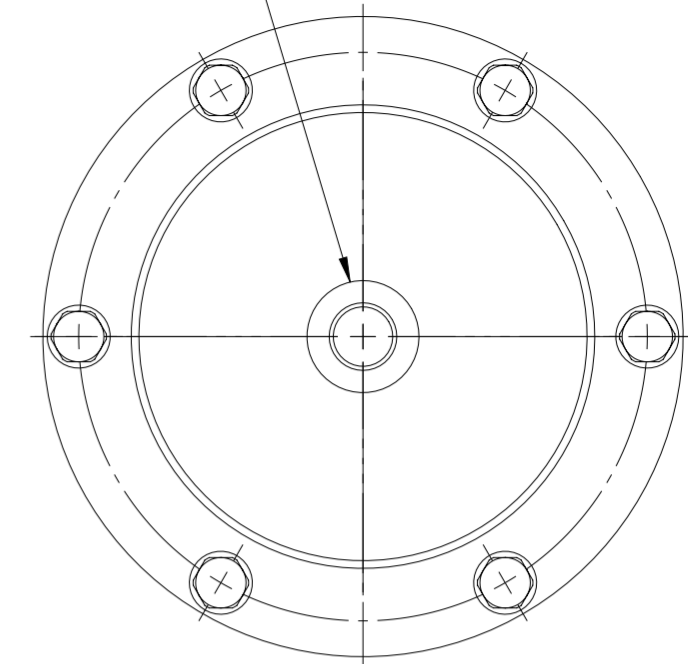

SPECIFICATION

- Cv: **K39:** 2.1. **K39S:** 3.0.
- MEDIUM: GAS AND LIQUID
- OXYGEN USE VARIANT AVAILABLE
- 2 PORT 2 POSITION (2/2)
- PRESSURE BIASED
- NORMALLY CLOSED
- PILOT MEDIUM: GAS AND LIQUID
- DRY WEIGHT: 2.10 kg (4.62 lb) (ALUMINIUM ALLOY)

NOTE - THIS PRODUCT HAS A RECOMMENDED MINIMUM OPERATING PRESSURE OF 100 Bar (1,450 psi) FOR LEAK-TIGHT OPERATION. CONTACT THE FACTORY FOR OTHER ALTERNATIVES.

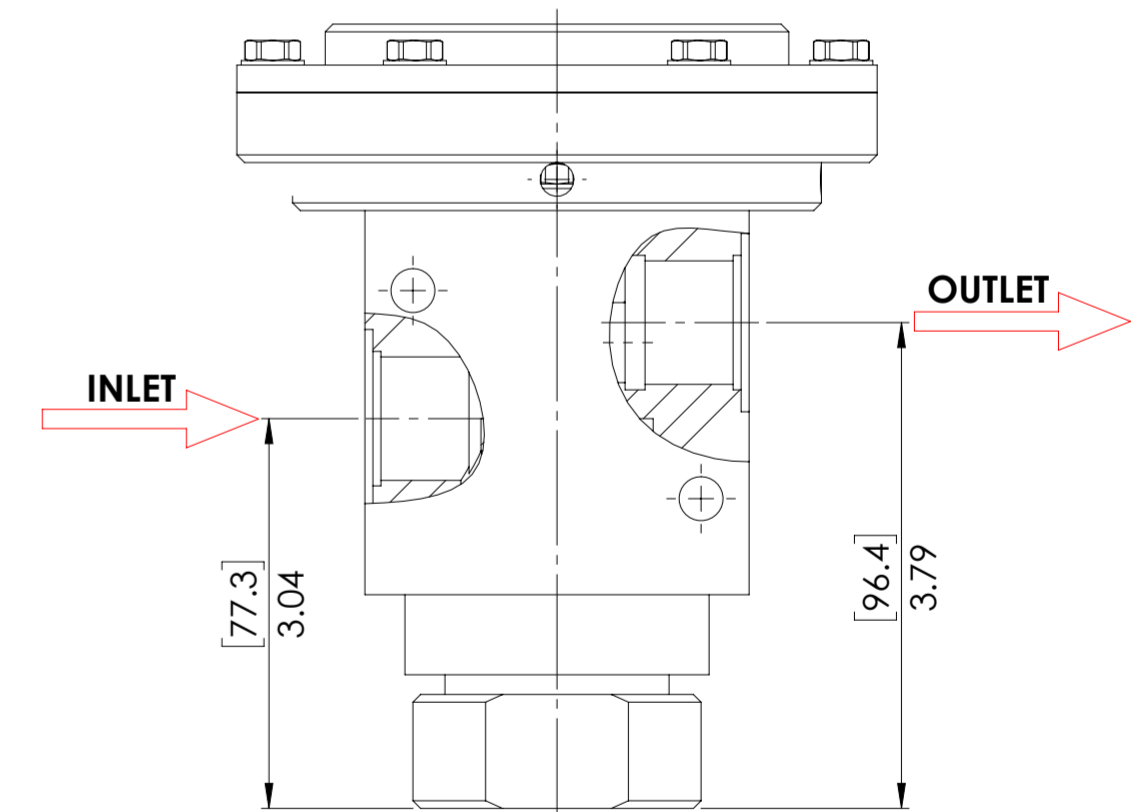
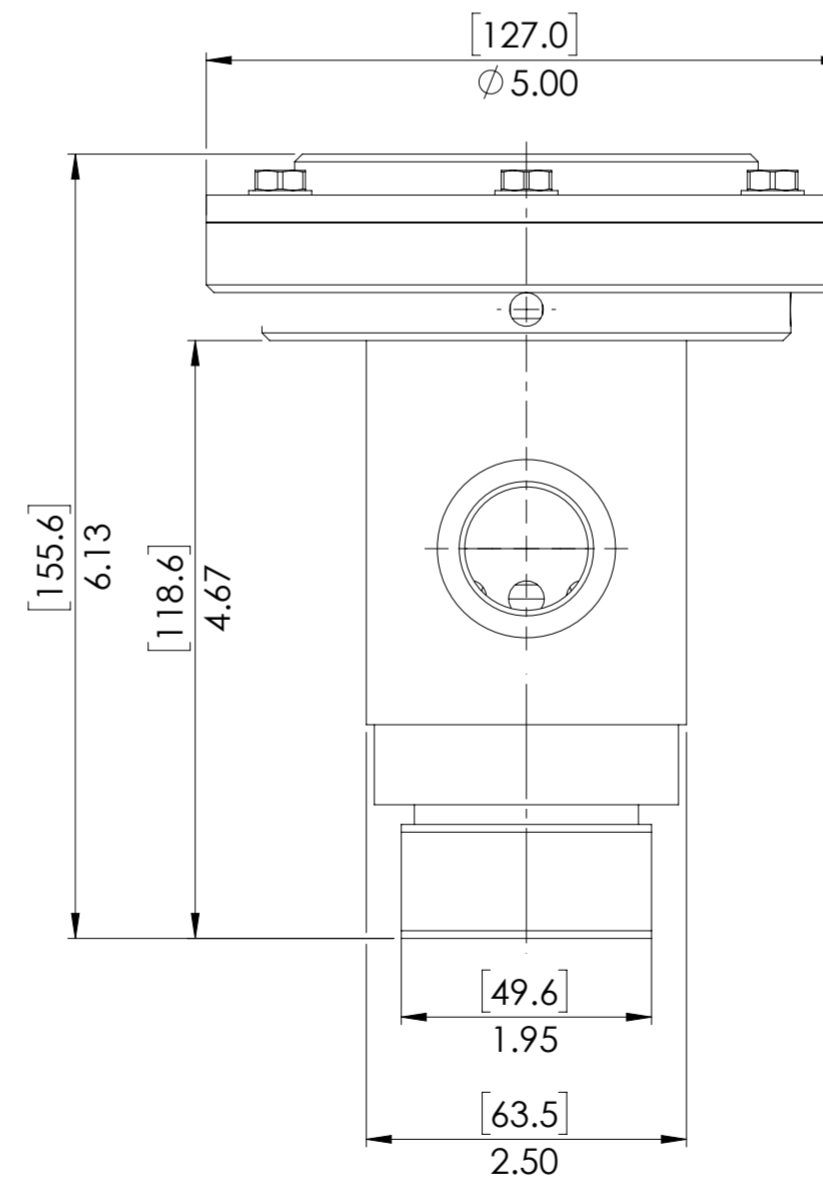
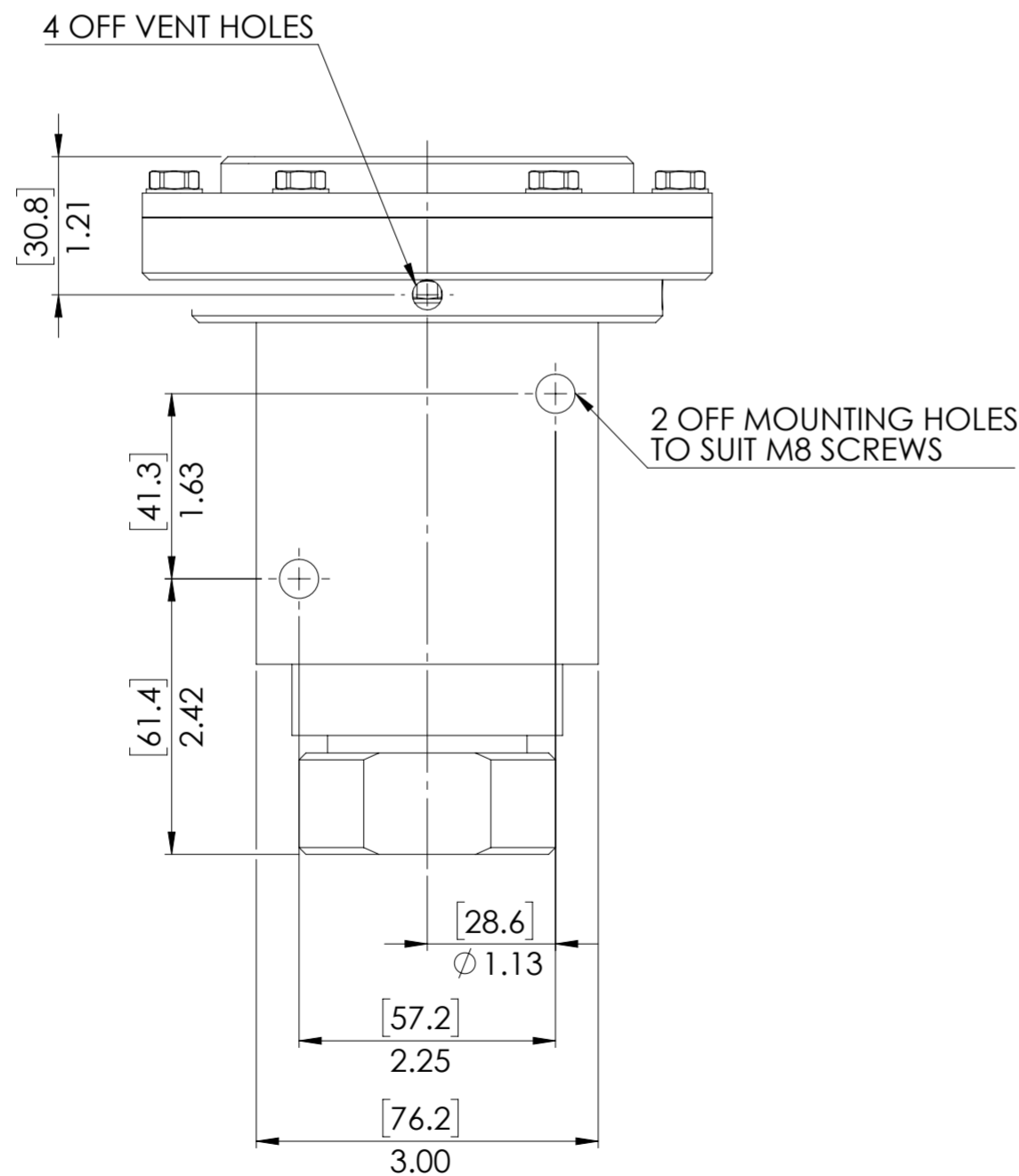
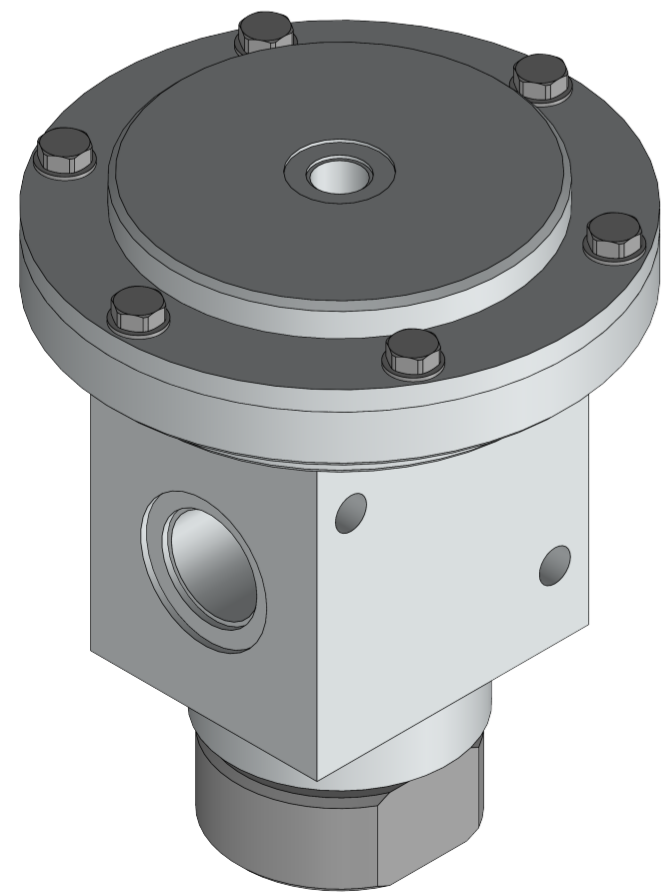

© AND DESIGN RIGHT BIS WELLS LTD. ALL RIGHTS RESERVED. WITHOUT THE PRIOR WRITTEN PERMISSION OF BIS WELLS LTD NO PART OF THIS DOCUMENT MAY BE ALTERED, ADAPTED, PUBLISHED, REPRODUCED OR TRANSMITTED IN ANY FORM OR MEDIUM.				UNLESS OTHERWISE SPECIFIED DIMENSIONS ARE IN INCHES 1. LINEAR TOLERANCES : ± 0.1 " 2. ANGULAR TOLERANCES : $\pm 2^\circ$						
DRAWN	N.DANIEL	SHEET	1 OF 1	3RD ANGLE PROJECTION	DRAWING SIZE	A2	DRAWING SCALE	2:3	DRAWING NUMBER	DS0041
DATE	21/02/20	ISSUE	2							