

DATASHEET

'T' FILTER: F22

MODEL CODE					
F22 -	3	10M	SS	37P	N

MODEL TYPE	
F22 -	'T' STYLE FILTER

MAXIMUM WORKING PRESSURE	
3	500 Bar (7,250 Psi)
4	700 Bar (10,150 Psi)
5	1,035 Bar (15,000 Psi)

FILTRATION	
5M	5 MICRON
10M	10 MICRON
25M	25 MICRON
37M	37 MICRON
100M	100 MICRON

SEAL MATERIAL	
N	NITRILE
V	FKM
E	EPDM

PORTS	
37P	3/8" BSP
37N	3/8" NPT
56AE	3/8" OD MP FEMALE
81AE	9/16" OD MP FEMALE

EXTERNAL MATERIAL	
SS	STAINLESS STEEL

2 OFF M6 MOUNTING HOLES

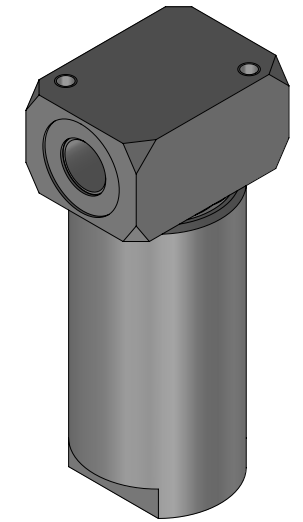
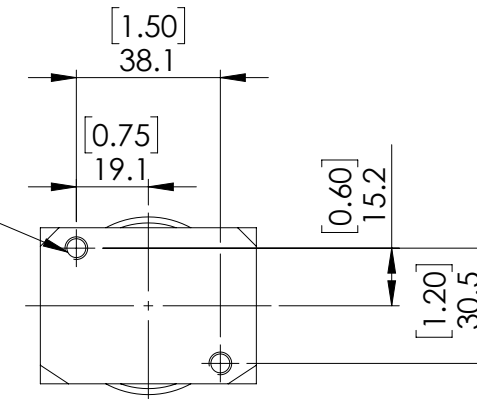

SPECIFICATION

- MEDIUM: GAS AND LIQUIDS
- DRY WEIGHT: 1.7 kg (3.75) lbs
- OTHER SEAL MATERIALS AVAILABLE ON REQUEST.
- FILTRATION MICRON RATINGS ARE NOMINAL.
- OTHER FILTRATION SIZES ARE AVAILABLE.
- FLOW CAPACITY IS DEPENDANT ON MANY FACTORS INCLUDING FILTRATION RATING, WORKING MEDIA, DUTY CYCLE, CLEANLINESS OF FLUID BEING FILTERED, AND REQUIRED MAINTENANCE INTERVALS. PLEASE CONTACT US WITH YOUR APPLICATION DETAILS TO OBTAIN A PRODUCT SIZING RECOMMENDATION.

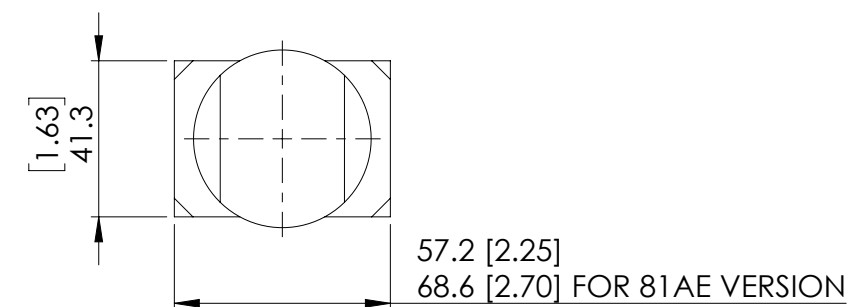
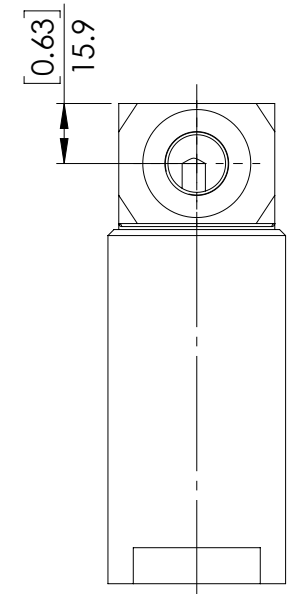
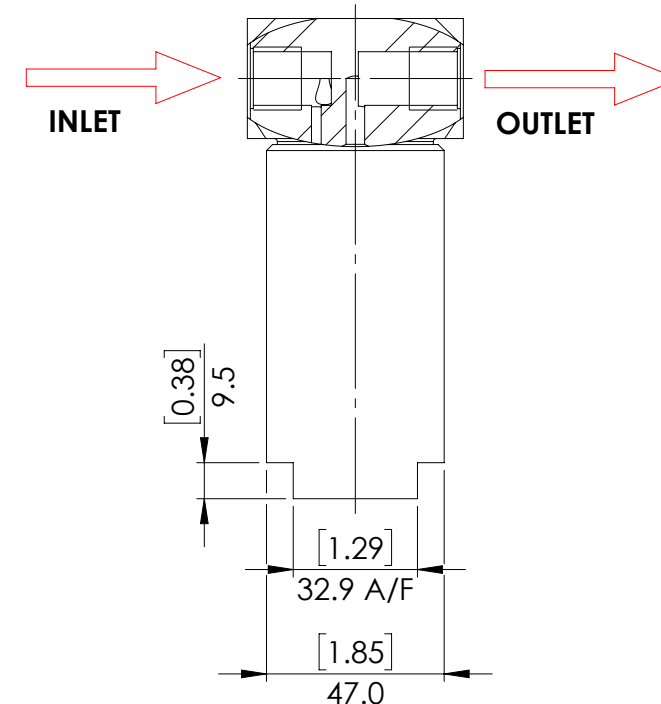
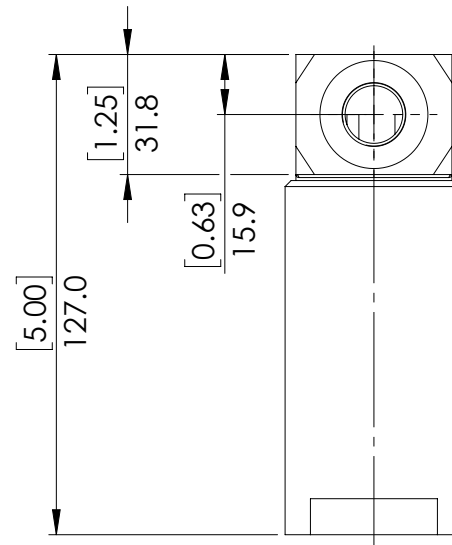

© AND DESIGN RIGHT Bis Wells LTD. ALL RIGHTS RESERVED. WITHOUT THE PRIOR WRITTEN PERMISSION OF Bis Wells Ltd NO PART OF THIS DOCUMENT MAY BE ALTERED, ADAPTED, PUBLISHED, REPRODUCED OR TRANSMITTED IN ANY FORM OR MEDIUM.

UNLESS OTHERWISE SPECIFIED DIMENSIONS ARE IN MILLIMETRES. ALTERNATIVE DIMENSIONS IN SQUARE BRACKETS ARE IN INCHES.

DRAWN N.Daniel	SHEET 1 OF 1		DRAWING SIZE A3	DRAWING SCALE 1:2	DRAWING NUMBER DS0038
DATE 18/02/20	ISSUE 2				