

DATASHEET

COALESCING 'T' FILTER: F24C (STAINLESS STEEL VERSION UP TO 700 BAR)

MODEL CODE					
F24C -	3	E	SS	50P	N

MODEL TYPE	F24C - COALESCING 'T' FILTER
------------	------------------------------

MAXIMUM WORKING PRESSURE	3 500 Bar (7,250 Psi)
	4 700 Bar (10,150 Psi)

FILTER ELEMENT BINDER	E EPOXY ESTER
-----------------------	---------------

SEAL MATERIAL	
N	NITRILE
V	FKM
E	EPDM

PORTS	
50P	1/2" BSPP
50N	1/2" NPT
81AE	9/16" MP FEMALE
75P	3/4" BSPP
75N	3/4" NPT

EXTERNAL MATERIAL	
SS	STAINLESS STEEL

SPECIFICATION

- MEDIUM: GASES
- DRY WEIGHT: 3.5 kg (7.71 lb)
3.9 kg (8.59 lb) FOR 81AE VERSION
- OTHER SEAL MATERIALS AVAILABLE ON REQUEST.
- FILTER ELEMENT STRUCTURE: BOROSILICATE GLASS MICROFIBRES WITH BINDER.
- 99.5% REMOVAL OF 0.01 MICRON PARTICLES AND AEROSOLS.
- PLEASE CONTACT US WITH YOUR APPLICATION DETAILS TO OBTAIN A RECOMMENDATION FOR PRODUCT SUITABILITY.

THIS DATASHEET RELATES TO THE STAINLESS STEEL VERSION WITH PRESSURES UP TO 700 BAR. CONTACT US FOR OTHER F24C DATASHEETS WITH OTHER MATERIALS AND PRESSURES UP TO 1,035 BAR.

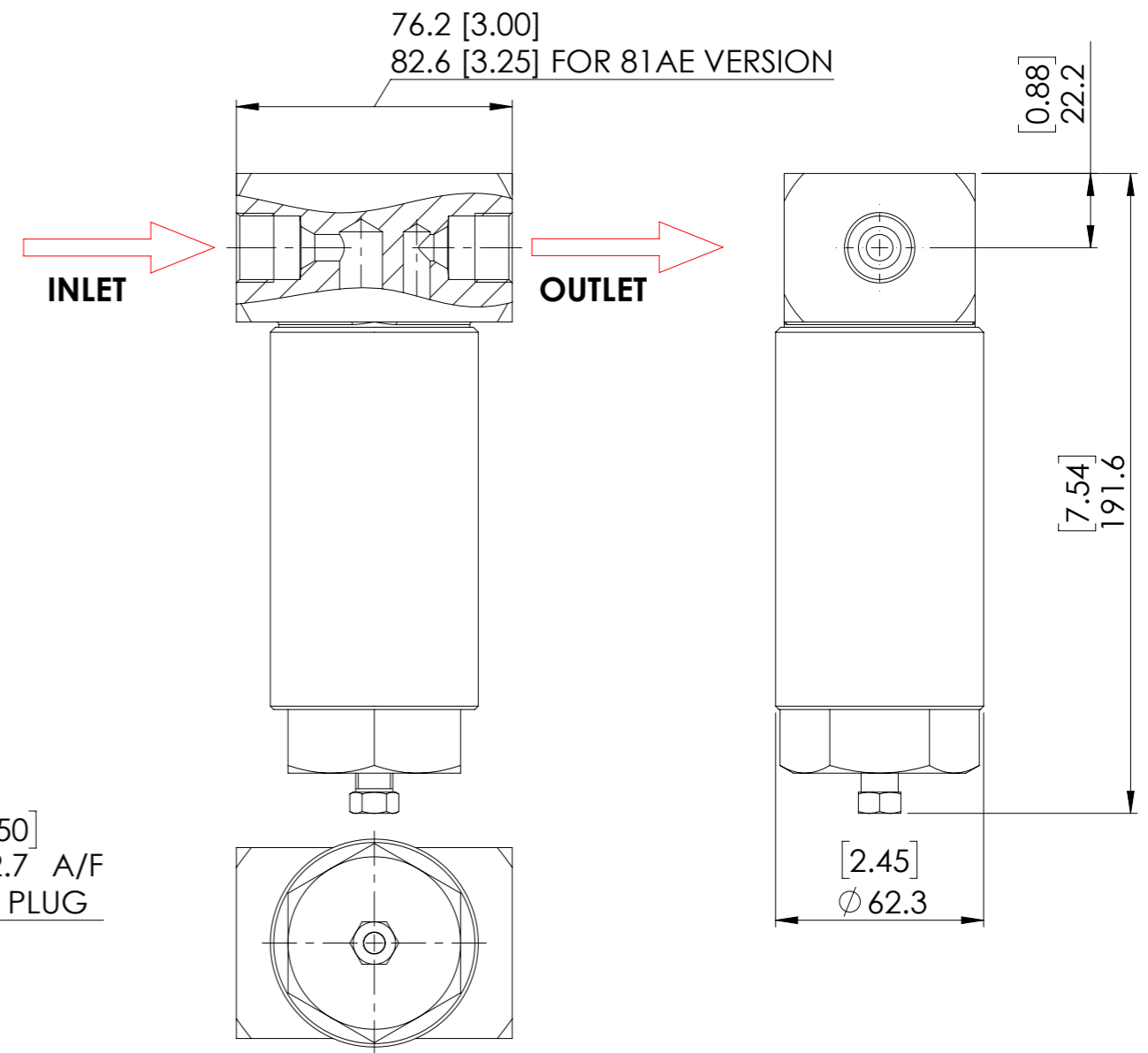
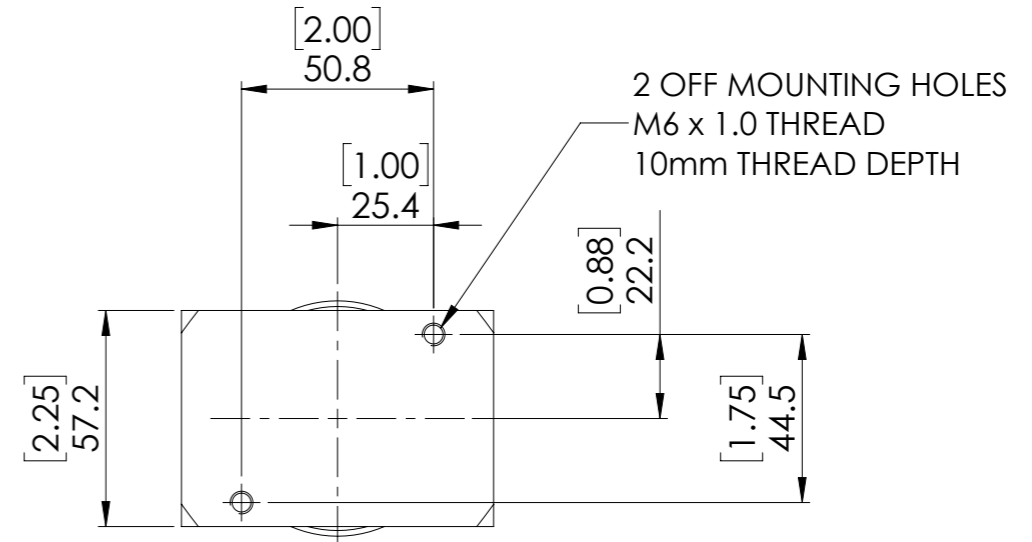
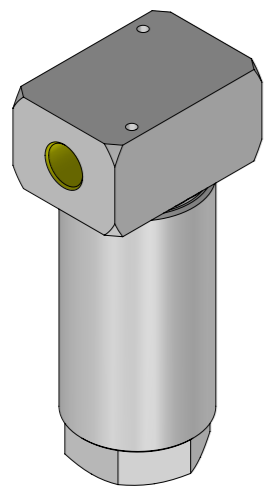

© AND DESIGN RIGHT BIS Wells LTD. ALL RIGHTS RESERVED. WITHOUT THE PRIOR WRITTEN PERMISSION OF BIS Wells Ltd NO PART OF THIS DOCUMENT MAY BE ALTERED, ADAPTED, PUBLISHED, REPRODUCED OR TRANSMITTED IN ANY FORM OR MEDIUM.					UNLESS OTHERWISE SPECIFIED DIMENSIONS ARE IN MILLIMETRES. ALTERNATIVE DIMENSIONS IN SQUARE BRACKETS ARE IN INCHES.	
DRAWN J. KIM	SHEET 1 OF 1	 3RD ANGLE PROJECTION	DRAWING SIZE A3	DRAWING SCALE 1:2	DRAWING NUMBER DS0110	
DATE 17/01/24	ISSUE 2					